

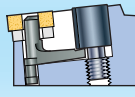

P

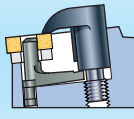







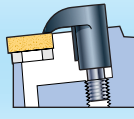

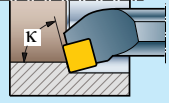

M

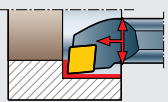

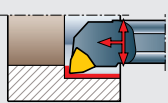
C

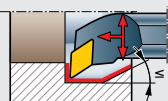
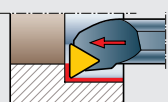
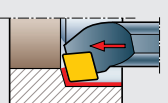
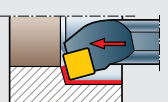

												Page Seite Sida	 Page: Seite: Sida: B19 - B21	
		8	10	12	16	20	25	32	40	50	60			
 95°	PCLN R/L MCLN R/L CCLN R/L						12	12	12		19		B80	
 95°	PWLN R/L MWLN R/L -						06 08	06 08	06 08				B80	
 93° $\leq 27^\circ$	PDUN R/L MDUN R/L CDUN R/L						11	11	15	15	15		B81	
 91°	PTFN R/L MTFN R/L CTFN R/L						16	16	16	22	22		B82	
 75°	PCKN R/L MCKN R/L CCKN R/L						12						B83	
 75°	PSKN R/L MSKN R/L CSKN R/L						12	12	12		15 19		B83	

Please note:

Holders in **M**-style **must** be used in combination with throw-away inserts which have an **insert height** according to **ISO** standard at the contact surface between the top of the clamp and the insert. If that would not be the case, as for example when using special cutting geometries with a pronounced positive rake angle, the top of the clamp will not touch the upper side of the insert and thereby the function of the **M**-clamping set will be negated.

Bitte beachten:

Halter in **M**-Ausführung dürfen **nur in Kombination** mit Wendeschneidplatten eingesetzt werden, deren **Höhe** zwischen Auflage und Spannfläche **ISO**-Standard entspricht. Wenn dies nicht gegeben ist, wie z B bei einigen speziellen Schneidengeometrien mit betont positivem Spanwinkel, berührt die Spannhakenase die Oberseite der Schneidplatte nicht. Dadurch wird die Funktion des **M**-Spannsatzes vereitelt.

Observera:

Hållare i **M**-utförande **måste** användas i kombination med vändskär som har en **skärhöjd** enligt **ISO**-standard vid spännhaksnosens anliggningsyta. Om så ej är fallet, som t ex vid användande av speciella skärgeometrier med uttalat positiv spånvinkel, kommer spännhakens nos ej i kontakt med skärets översida och därmed omintetgör **M**-spännsatsens funktion.

Holders with **P**- and **M**-clamping are stocked in accordance with the range shown in the catalogue.

Holders with **C**-clamping in the **PMC**-range are not stocked. The **C**-holder is obtained in the following way:

- From the **P**-holder:
Remove the locking pin (LP) and change the clamping set (PS) for the clamping set MS in accordance with the sketch on page B16.

The spare part designation on the clamping set (MS) is obtained from the table on corresponding holder size in **M**-version.

- From the **M**-holder:
Remove the locking pin (LP) in accordance with sketch on page B16.

The **MIRCONA PMC** system is patented and patent pending in many countries.

Halter mit **P**- und **M**-Spannsystem werden am Lager gehalten entsprechend der Aufstellung, die im Katalog gezeigt wird.

Halter mit **C**-Spannsystem werden in der **PMC**-Produktpalette nicht am Lager gehalten. Die **C**-Ausführung erhält man wie folgt:

- Aus dem **P**-Halter:
Entfernen Sie den Spannstift (LP) und wechseln Sie den Spannsatz (PS) gegen den Spannsatz (MS) entsprechend der Skizze auf Seite B16.

Die Ersatzteilbeschreibung des Spannringes (MS) erhalten Sie aus der Tabelle für die entsprechende Haltergröße in **M**-Ausführung.

- Aus dem **M**-Halter:
Entfernen Sie den Spannstift (LP) entsprechend der Skizze auf Seite B16.

Das **MIRCONA PMC**-system ist in mehreren Ländern patentiert und zum Patent angemeldet.

Hållare med **P**- och **M**-fastspänning lagervärdas i överensstämmelse med sortimentet i katalogen.

Hållare med **C**-fastspänning i **PMC**-sortimentet lagervärdas ej. **C**-utförandet erhålles på följande sätt:

Ifrån **P**-hållaren:
Ta bort låspinnen (LP) och byt spännsats (PS) mot spännsats (MS) enl skiss på sid B16.

Reservdelsbeteckningen på spännsats (MS) erhålles ifrån tabellen på motsvarande hållarstorlek i **M**-utförande.

- Ifrån **M**-hållaren:
Ta bort låspinnen (LP) enl skiss på sid B16.

MIRCONA PMC-system är patenterat och patentsökt i ett flertal länder.



**PCLN R/L
MCLN R/L
CCLN R/L**

Recommendations
Empfehlungen
Rekommendationer

Page: Seite: **B9-B14**
Sida:

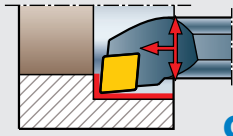

95°

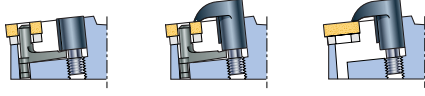

P

M

C

The drawing shows right-hand version. Left-hand version reversed.
Die Zeichnung zeigt Rechtsausführung. Linksausführung umgekehrt.
Ritningen visar högerutförande. Vänsterutförande spegelvänt.

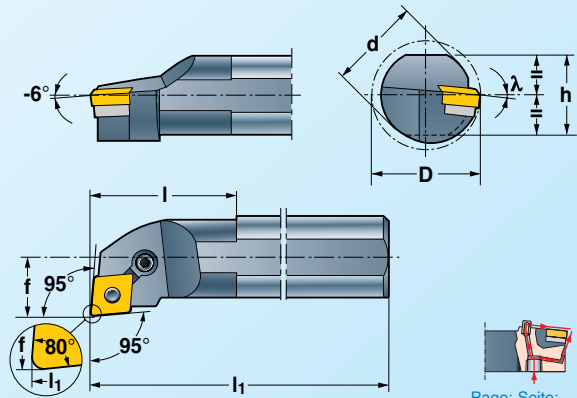

EB

Page: Seite: **B19 - B21**
Sida:

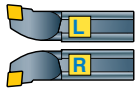

d	h	l ₁	l	f	D _{min}	λ							
---	---	----------------	---	---	------------------	---	--	--	--	--	--	--	--

CNMA*
CNMM
CNMG
Page: Seite: **B137-B142**
Sida:

P	S25S-PCLN R/L 12	25	23	250	40	17	32	-14°	LP62K-1	UCN12	RS62	D62	PS62K	-	NY4	1204 ..
	S32T-PCLN R/L 12	32	30	300	45	22	40	-10°								
	S40U-PCLN R/L 12	40	37	350	60	27	50	-10°								
	S50V-PCLN R/L 19	50	47	400	80	35	63	-10°	LP65	UCN19	RS65	D65	PS62	-	NY4	1906 ..
M	S25S-MCLN R/L 12	25	23	250	40	17	32	-14°	LP62K-1	UCN12	RS62	D62	-	MS62K	NY4	1204 ..
	S32T-MCLN R/L 12	32	30	300	45	22	40	-10°								
	S40U-MCLN R/L 12	40	37	350	60	27	50	-10°								
	S50V-MCLN R/L 19	50	47	400	80	35	63	-10°	LP65	UCN19	RS65	D65	-	MS63	NY4	1906 ..
C	CCLN R/L	See page – Siehe Seite – Se sida B13-B14														

**PWLN R/L
MWLN R/L**

Recommendations
Empfehlungen
Rekommendationer

Page: Seite: **B9-B14**
Sida:

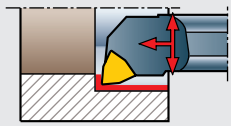

95°

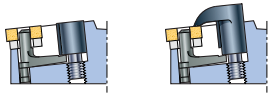

P

M

The drawing shows right-hand version. Left-hand version reversed.
Die Zeichnung zeigt Rechtsausführung. Linksausführung umgekehrt.
Ritningen visar högerutförande. Vänsterutförande spegelvänt.

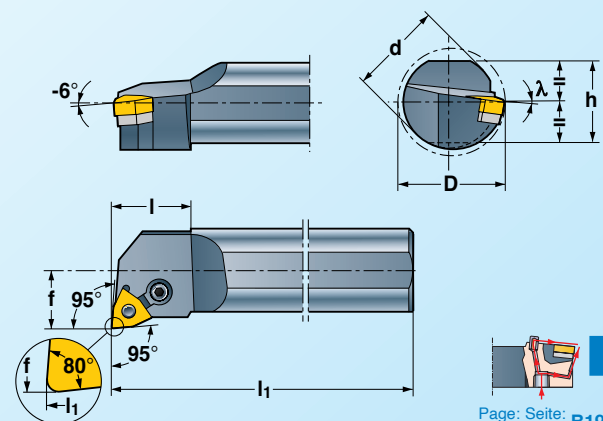

EB

Page: Seite: **B19 - B21**
Sida:

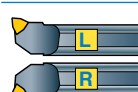

d	h	l ₁	l	f	D _{min}	λ							
---	---	----------------	---	---	------------------	---	--	--	--	--	--	--	--

WNMA*
WNMM
WNMM
Page: Seite: **B137-B142**
Sida:

P	S25S-PWLN R/L 06T	25	23	250	40	17	32	-14°	LP61-1	UWN06	RS61K	D61	PS61	-	NY 3	0604 ..
	S32T-PWLN R/L 06T	32	30	300	40	22	40	-12°								
	S40U-PWLN R/L 06T	40	37	350	40	27	50	-10°								
	S25S-PWLN R/L 08T	25	23	250	40	17	32	-14°	LP62K-1	UWN08	RS62	D62	PS62K	-	NY 4	0804 ..
	S32T-PWLN R/L 08T	32	30	300	40	22	40	-14°								
	S40U-PWLN R/L 08T	40	37	350	40	27	50	-12°								
M	S25S-MWLN R/L 06T	25	23	250	40	17	32	-14°	LP61-1	UWN06	RS61K	D61	-	MS61	NY 3	0604 ..
	S32T-MWLN R/L 06T	32	30	300	40	22	40	-12°								
	S40U-MWLN R/L 06T	40	37	350	40	27	50	-10°								
	S25S-MWLN R/L 08T	25	23	250	40	17	32	-14°	LP62K-1	UWN08	RS62	D62	-	MS62K	NY 4	0804 ..
	S32T-MWLN R/L 08T	32	30	300	40	22	40	-14°								
	S40U-MWLN R/L 08T	40	37	350	40	27	50	-12°								

- * Selection of cutting geometry page:
 Wahl der Schneidgeometrie, Seite: **B22-B26**
 Val av skärgeometri, sid:

Ordering example:

Bestellbeispiel: **S50V-PCLNL 19**

Beställningsexempel:

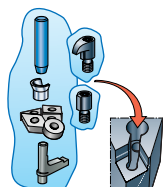

Spare parts shown in the coloured columns are supplied assembled in each tool.

Die in den farbigen Spalten aufgeführten Ersatzteile sind in den Werkzeugen montiert.

Reservdelar i de färgade kolumnerna ingår monterade i varje verktyg.



PDUN R/L MDUN R/L

Recommendations
Empfehlungen
Rekommendationer

Page: Seite: **B9-B14**
Sida:

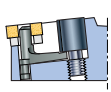
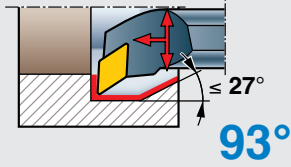

P

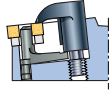

M

The drawing shows right-hand version. Left-hand version reversed.
Die Zeichnung zeigt Rechtsausführung. Linksausführung umgekehrt.
Ritningen visar högerutförande. Vänsterutförande spegelvänt.

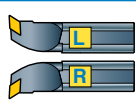
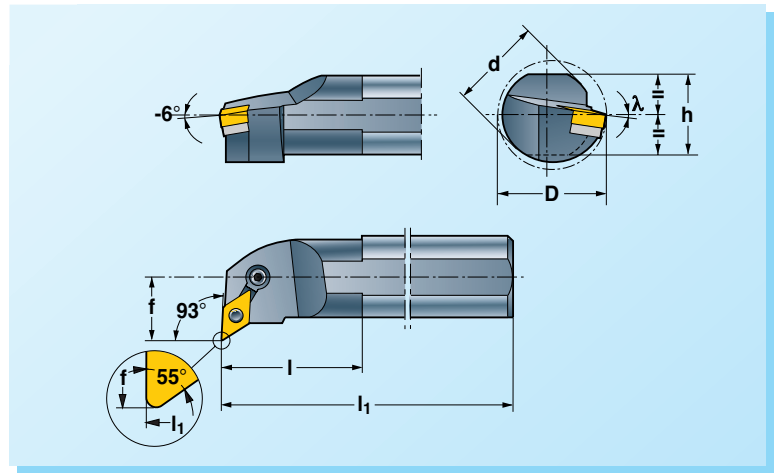

d	h	l ₁	l	f	D _{min}	λ
---	---	----------------	---	---	------------------	---

DNMA		Page: B137-B142
DNMM		Seite:
DNMG		Sida:

	d	h	l ₁	l	f	D _{min}	λ	LP	UDN	RS	D	PS	MS	NY	DNMA*
P S25S-PDUN R/L 11 S32T-PDUN R/L 11	25 32	23 30	250 300	26 30	17 22	32 40	-11° -10°	LP61-1	UDN11	RS61K	D61	PS61	—	NY3	1104..
S32T-PDUN R/L 15T S40U-PDUN R/L 15T S50V-PDUN R/L 15T	32 40 50	30 37 47	300 350 400	45 60 75	22 27 35	40 50 63	-10° -10° -10°	LP62-1T	UDN15 ³⁾ (UDN154) ⁴⁾	RS62	D62	PS62K	—	NY4	1506 . . ³⁾ (1504 . .) ⁴⁾
M S25S-MDUN R/L 11 S32T-MDUN R/L 11	25 32	23 30	250 300	26 30	17 22	32 40	-11° -10°	LP61-1	UDN11	RS61K	D61	— —	MS61T-K MS61T	NY3	1104..
S32T-MDUN R/L 15T S40U-MDUN R/L 15T S50V-MDUN R/L 15T	32 40 50	30 37 47	300 350 400	45 60 75	22 27 35	40 50 63	-10° -10° -10°	LP62-1T	UDN15 ³⁾ (UDN154) ⁴⁾	RS62	D62	—	MS63K	NY4	1506 . . ³⁾ (1504 . .) ⁴⁾

CDUN R/L See page — Siehe Seite — Se sida **B13-B14**

³⁾ Standard delivery for inserts with 6.35 mm thickness.
⁴⁾ Separate delivery for inserts with 4.76 mm thickness.

³⁾ Standardlieferung für Schneiden mit 6.35 mm Dicke.
⁴⁾ Lieferung auf besondere Bestellung für Schneiden mit 4.76 mm Dicke.

³⁾ Standardleverans för skär med 6.35 mm tjocklek.
⁴⁾ Separat leverans för skär med 4.76mm tjocklek.

PTFN R/L
MTFN R/L
CTFN R/L

Recommendations
Empfehlungen
Rekommendationer

Page: Seite: **B9-B14**
Sida:

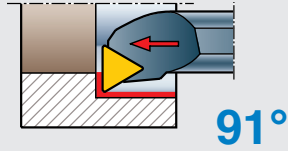

91°

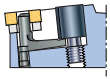

P

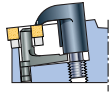

M

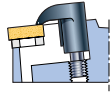

C

The drawing shows right-hand version. Left-hand version reversed.
Die Zeichnung zeigt Rechtsausführung. Linksausführung umgekehrt.
Ritningen visar högerutförande. Vänsterutförande spegelvänt.

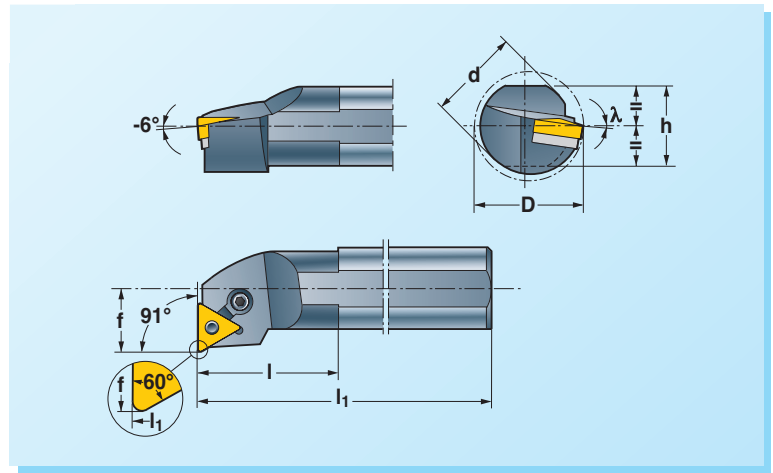

		d	h	l ₁	l	f	D _{min}	λ								TNMA	TNMM	TNMG	Page: Seite: Sida:
P	S25S-PTFN R/L 16 S32T-PTFN R/L 16 S40U-PTFN R/L 16	25 32 40	23 30 37	250 300 350	40 45 60	17 22 27	32 40 50	-14° -12° -12°	LP61	UTN16-1 ¹⁾ (UTN16-2) ²⁾	RS61K ¹⁾ (RS61) ²⁾	D61	PS61	—	NY3	1604 .. ¹⁾ (1603 ..) ²⁾			B137-B142
	S40U-PTFN R/L 22 S50V-PTFN R/L 22	40 50	37 47	350 400	60 70	27 35	50 63	-6° -6°	LP62K-1	UTN22	RS62	D62	PS62	—	NY4	2204 ..			
M	S25S-MTFN R/L 16 S32T-MTFN R/L 16 S40U-MTFN R/L 16	25 32 40	23 30 37	250 300 350	40 45 60	17 22 27	32 40 50	-14° -12° -12°	LP61	UTN16-1 ¹⁾ (UTN16-2) ²⁾	RS61K ¹⁾ (RS61) ²⁾	D61	—	MS61	NY3	1604 .. ¹⁾ (1603 ..) ²⁾			
	S40U-MTFN R/L 22 S50V-MTFN R/L 22	40 50	37 47	350 400	60 70	27 35	50 63	-6° -6°	LP62K-1	UTN22	RS62	D62	—	MS62	NY4	2204 ..			
C	CTFN R/L	See page — Siehe Seite — Se sida B13-B14																	

¹⁾ Standard delivery for inserts with 4.76 mm thickness.
²⁾ Separate delivery for inserts with 3.18 mm thickness.

¹⁾ Standardlieferung für Schneiden mit 4,76 mm Dicke.
²⁾ Lieferung auf besondere Bestellung für Schneiden mit 3,18 mm Dicke.

¹⁾ Standardleverans för skär med 4,76 mm tjocklek.
²⁾ Separat leverans för skär med 3,18 mm tjocklek.

*
 Selection of cutting geometry page:
 Wahl der Schneidgeometrie, Seite: **B22-B26**
 Val av skärgeometri, sid:

Ordering example:
Bestellbeispiel: **S50V-PDUNL 15T**
Beställningsexempel:

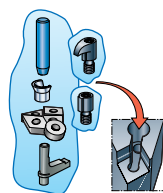

Spare parts shown in the coloured columns are supplied assembled in each tool.

Die in den farbigen Spalten aufgeführten Ersatzteile sind in den Werkzeugen montiert.

Reservdelar i de färgade kolumnerna ingår monterade i varje verktyg.

**PCKN R/L
MCKN R/L
CCKN R/L**

Recommendations
Empfehlungen
Rekommendationer

Page: Seite: **B9-B14**
Sida:

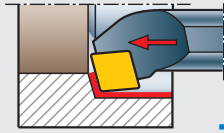

75°

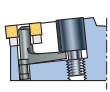

P

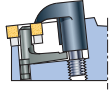

M

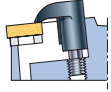

C

The drawing shows right-hand version. Left-hand version reversed.
Die Zeichnung zeigt Rechtsausführung. Linksausführung umgekehrt.
Ritningen visar högerutförande. Vänsterutförande spegelvänt.

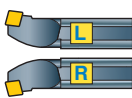
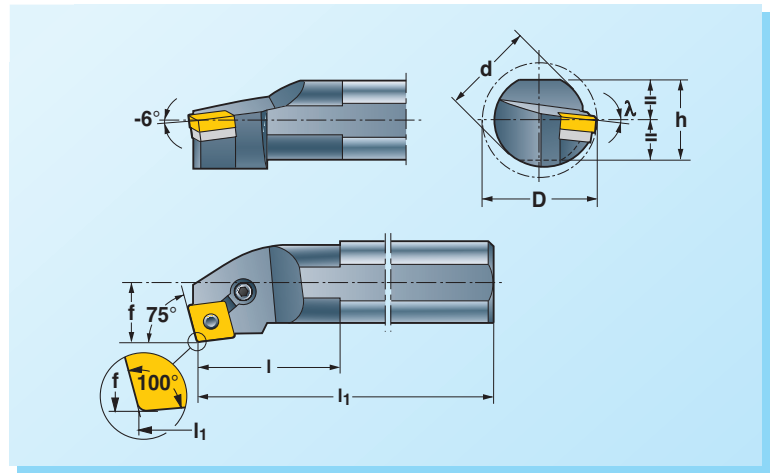

d

h

l₁

l

f

D_{min}

λ



CNMA *
CNMM
CNMG

Page: Seite: **B137-B142**
Sida:

P	S25S-PCKN R/L 12	25	23	250	40	17	32	-14°	LP62K-1	UCN12	RS62	D62	PS62K	—	NY4	1204 ..
M	S25S-MCKN R/L 12	25	23	250	40	17	32	-14°	LP62K-1	UCN12	RS62	D62	—	MS62K	NY4	
C	CCKN R/L	See page – Siehe Seite – Se sida B13-B14														

**PSKN R/L
MSKN R/L
CSKN R/L**

Recommendations
Empfehlungen
Rekommendationer

Page: Seite: **B9-B14**
Sida:

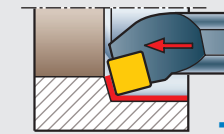

75°

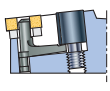

P

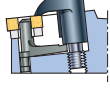

M

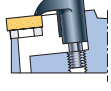

C

The drawing shows right-hand version. Left-hand version reversed.
Die Zeichnung zeigt Rechtsausführung. Linksausführung umgekehrt.
Ritningen visar högerutförande. Vänsterutförande spegelvänt.

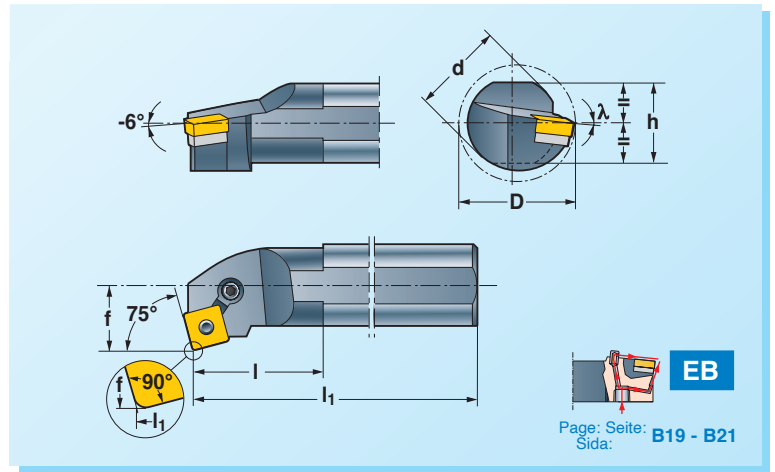

P	S25S-PSKN R/L 12	25	23	250	40	17	32	-14°	LP62K-1	USN12	RS62	D62	PS62K	—	NY4	1204 ..
	S32T-PSKN R/L 12	32	30	300	45	22	40	-10°								
	S40U-PSKN R/L 12	40	37	350	60	27	50	-10°								
	S50V-PSKN R/L 15	50	47	400	70	35	63	-10°	LP64	USN15	RS64	D64	PS62	—	NY4	1506 ..
	S50V-PSKN R/L 19	50	47	400	70	35	63	-10°	LP65	USN19	RS65	D65	PS62	—	NY4	1906 ..
M	S25S-MSKN R/L 12	25	23	250	40	17	32	-14°	LP62K-1	USN12	RS62	D62	—	MS62K	NY4	1204 ..
	S32T-MSKN R/L 12	32	30	300	45	22	40	-10°								
	S40U-MSKN R/L 12	40	37	350	60	27	50	-10°								
	S50V-MSKN R/L 15	50	47	400	70	35	63	-10°	LP64	USN15	RS64	D64	—	MS63	NY4	1506 ..
	S50V-MSKN R/L 19	50	47	400	70	35	63	-10°	LP65	USN19	RS65	D65	—	MS63	NY4	1906 ..
C	CSKN R/L	See page – Siehe Seite – Se sida B13-B14														

- * Selection of cutting geometry page: **B22-B26**
- Wahl der Schneidgeometrie, Seite:
- Val av skärgeometri, sid:

Ordering example:
Bestellbeispiel: **S50V-MSKNL 19**
Beställningsexempel:

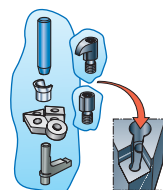

Spare parts shown in the coloured columns are supplied assembled in each tool.

Die in den farbigen Spalten aufgeführten Ersatzteile sind in den Werkzeugen montiert.

Reservdelar i de färgade kolumnerna ingår monterade i varje verktyg.